



smart scanning

SCANLAB's intelliSCAN **scan heads** stand out with variant diversity and high dynamics. They're among the **2D scan systems** that enable deflecting and positioning of laser beams in the working plane.

Key Features

- Highest dynamic performance
- Maximum flexibility due to switchable tunings
- Ideal adaptability enabled by a multitude of variants
- Comprehensive diagnostic and monitoring functions
- High long-term stability
- Water & air cooling option

The intelliSCAN series allows versatile and flexible usage. It's designed for tasks with very high scan requirements across a broad variety of application areas.

Typical Applications

- Additive manufacturing (3D printing)
- Materials processing, micro-structuring
- Marking, welding, drilling
- Processing-on-the-fly

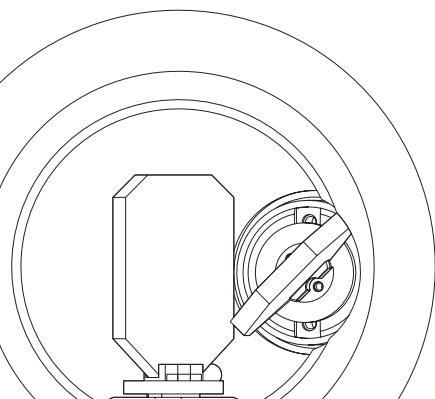

Range of intelliSCAN Product Lines

- **intelliSCAN**
(10, 14, 20 and 30 mm apertures)
- **intelliSCANIII**
(10, 14, 20 and 30 mm apertures)
- **intelliSCAN_{se}**
(10 and 14 mm apertures)
- **intelliSCAN_{de}**
(14, 20 and 30 mm apertures)

Advantages of intelliSCAN series

- Variant diversity (customer-specific tunings, assorted housings and cooling methods)
- High extendibility (e.g. z-axes, camera adapter)
- Application-specific and customer-specific tunings
- Lower heat generation due to digital control

Advantages of iDRIVE technology

- Digital servo electronics provides improved dynamics and higher marking quality
- Up to three switchable tunings reduce process times
- Comprehensive diagnostics and communication possibilities between the scan system and RTC
- Acquisition of all key state variables in real time

Options & Variants

Housing Variants

- Standard water cooling (optional 10 mm and 14 mm aperture)
- Standard air cooling (20 mm and 30 mm aperture)
- Available as a scan module without housing (not all apertures)

Extensions

- varioSCAN: Extension into a 3-axis scan system
- excelliSHIFT: Extension into a high-speed, 3-axis scan system
- Camera adapter for optical process monitoring

Optics

- Over 50 standard coatings for various wavelengths (UV to infrared)
- Extensive variety of objectives
- High-performance variants with light-weight mirrors
- Customer-specific variants possible

Control Boards

- RTC5 and RTC6 (PCIe, Ethernet)

Software

- Application-specific and customer-specific tunings (servo algorithms and parameter sets) available
- laserDESK: professional software for laser marking and materials processing
- SCANalign: software for automatic and exact placement of laser beams; process integratable high-precision calibration solution
- Flexible calibration solutions: correXion pro, CALsheet



Laser drilling/Laser cutting



3D laser sintering

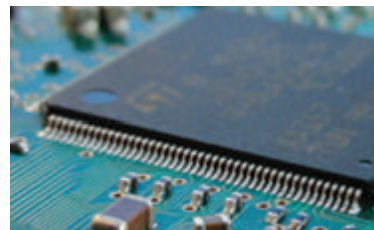

Marking

Scan Heads with Analog Position Detectors

intelliSCAN and intelliSCAN III

Analog Position Detectors

The position detector (PD, angle transmitter) is a critical galvanometer scanner component that determines the entire scan system's accuracy.

SCANLAB's standard portfolio of galvanometer scanners with analog optical position detectors currently comprises two product generations (dynAXIS and dynAXIS 3). Both of them work according to the same shadowing principle.

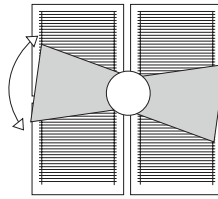

Analog Technology

- Working principle of an analog position detector with proportionate shadowing of different photo diodes.

intelliSCAN III Scan Heads

intelliSCAN III scan heads take advantage of dynAXIS 3 galvanometer scanners. Among them, the lighting of the position detector was optimized.

With the following benefits:

- Highest dynamic performance
- Low drift values
- Very good linearity.

Scan Heads with Digital Encoders

intelliSCAN_{de} and intelliSCAN_{se}

Digital encoder technology

The scan heads with digital encoder technology achieve superior positioning accuracy and long-term stability thus they are especially suited for high-end applications.

Compared to analog position detectors, they are characterized by:

- Highest precision due to the PD signal's low noise (lowest dither values)
- Very high long-term stability and Linearity
- Ideal for applications that demand highest throughput and precision
- SL2-100 interface supports 20-bit resolution with a SCANLAB RTC5/RTC6 control board
- Ensures highest processing accuracy thanks to excellent noise immunity

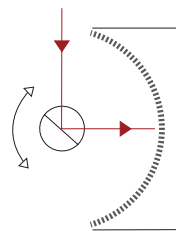

se-encoder Technology

- Interferometric principle of operation
- SCANLAB patented technology employs a "light pointer encoder" with reduced inertia mirror at rotor end

intelliSCAN_{se} scan heads

- The dynAXIS_{se} galvanometer scanners used here deliver superlative precision
- Best quality with a very good price/performance ratio
- Fastest scan head with 10-mm aperture and digital encoder

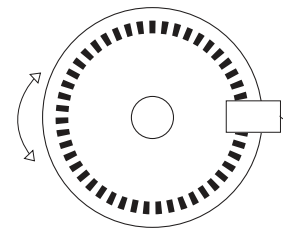

de-encoder Technology

- Galvanometer scanners based on digital encoder disk with radial graduated scale

intelliSCAN_{de} scan heads

- Very low dither and lowest drift values with highest linearity
- Industrial proven digital encoder technology

Principle

Tuning refers to a scan system's dynamics configuration. It's a fine adjustment of the digital servo control that determines the scan system's dynamic reactions while driven with a scan pattern.

Digital systems with *iDRIVE* technology – such as the *intelliSCAN* – can store up to three tunings in memory. Switching between those tunings is possible even during marking.

Always the ideal tuning

Special tunings can optimize scan systems to meet diverse requirements, such as for vectors, jumps or micro-machining.

Application-specific tunings bring increased speed and positioning accuracy. The digitally implemented output stages reduce heat generation, leading to improved temperature stability.

What kinds of tunings are available?

Most tunings are characterized by tracking error and maximum speed.

Low tracking error facilitates spatially-small/intricate marking, but accompanied by limited maximum speed. In contrast, elevating speed will also increase tracking error.

Jump tuning is a special case where jump times are minimized for long jumps, resulting in complete elimination of constant tracking error. Jump tuning is particularly well-suited for drilling applications.

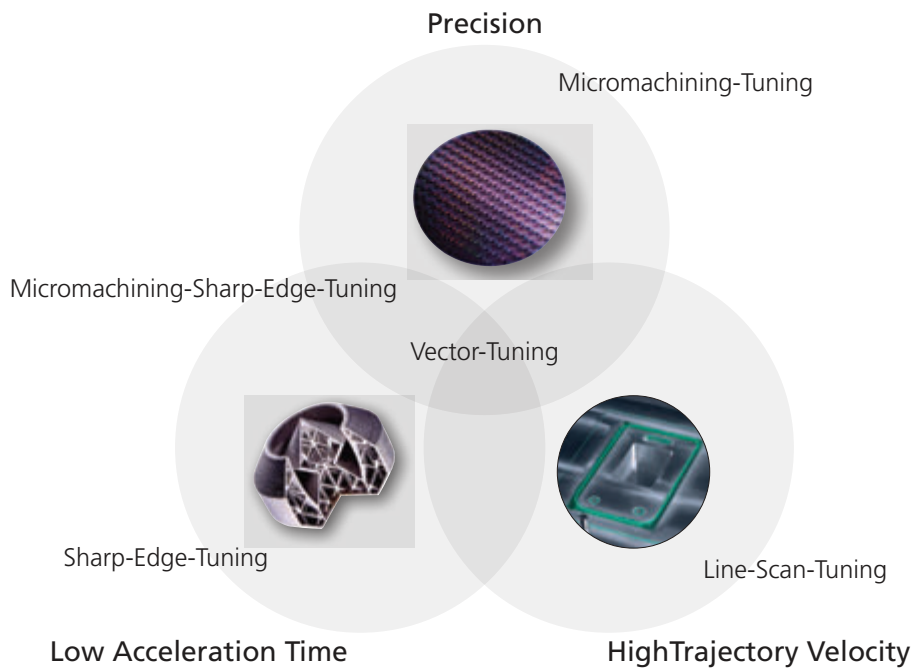

Overview of selected tunings

Some tunings aren't available for every aperture and variant!

Tuning	Optimized for	Application
Fast vector tuning	balanced optimum of all parameters in a wide range of applications	vector marking
Step tuning	minimal step response time	drilling, perforating
Sharp edge tuning	low acceleration time, small edge rounding	micro structures
Micromachining tuning	low dither, low line waviness	vector marking, micro structures
Micromachining-sharp edge tuning	low acceleration time, low dither	micro structures
Line scan tuning	highest marking speed (limitation: higher acceleration time)	ultrashort pulse laser processing

intelliSCAN 10, 14
 intelliSCANIII 10, 14
 intelliSCAN_{se} 10, 14
 intelliSCAN_{de} 14

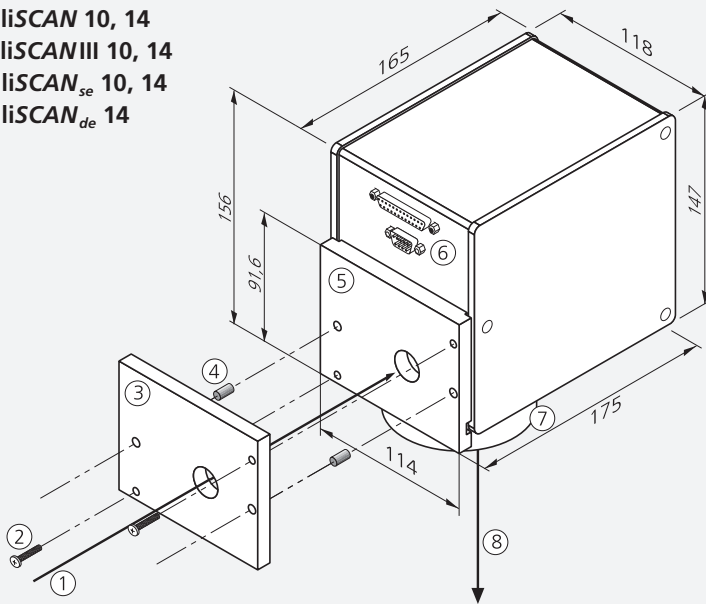

Beam exit side

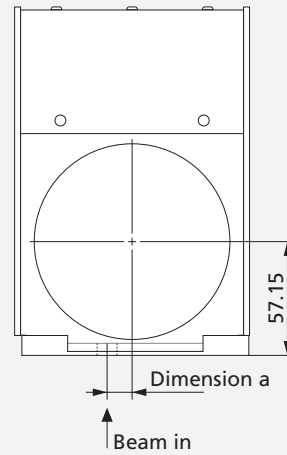

Denoted dimensions refer to the **standard housing type** (with standard mounting bracket).
 Variations in size and form are possible; also housings with water cooling have other dimensions.

intelliSCAN 20, 30
 intelliSCANIII 20, 30
 intelliSCAN_{de} 30

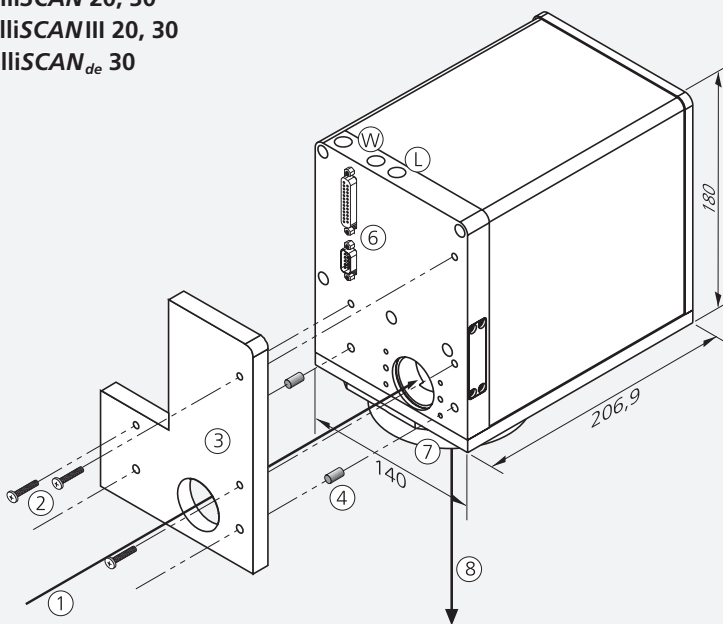

Beam exit side

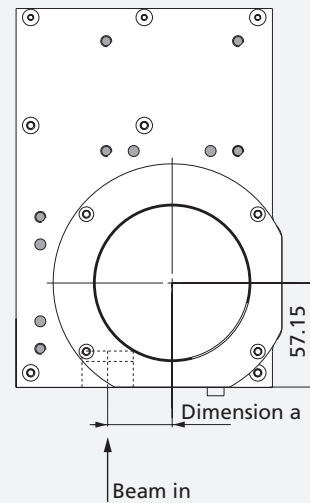

Legend

- | | | |
|--------------------------------------|-------------------------|---------------------------------|
| 1 Beam in | 5 Mounting bracket | A Connection for cooling air |
| 2 Screws (M6 threads)* | 6 Electrical connectors | W Connections for cooling water |
| 3 Flange* | 7 Objective | |
| 4 Alignment pins (6 _{re})* | 8 Beam out | |
- (* not included)

all dimensions in mm

Dimensions

	10 mm	14 mm	20 mm	30 mm
Aperture	10 mm	14 mm	20 mm	30 mm
Beam displacement (dimension a)	12.56 mm	16.42 mm	25.25 mm	35.53 mm
Weight	approx. 3 kg	approx. 3 kg	approx. 5.8 kg	approx. 5.8 kg

Specifications

Dynamics (for selected tunings)

	intelliSCAN 10	intelliSCAN 14	intelliSCAN 20	intelliSCAN 30
Product line	intelliSCAN intelliSCAN III intelliSCAN _{se}	intelliSCAN intelliSCAN III intelliSCAN _{se} intelliSCAN _{de}	intelliSCAN intelliSCAN III intelliSCAN _{de}	intelliSCAN intelliSCAN III intelliSCAN _{de}
Aperture [mm]	10	14	20	30
Tuning	Fast Vector	Sharp Edge	Fast Vector	Fast Vector
Tracking error [ms]	0.11	0.15	0.32	0.55
Typical speeds ⁽¹⁾				
Marking speed [m/s]	3.5	2.0	1.0	0.7
Positioning speed [m/s]	12.0	5.0	11.0	9.0
Writing speed [cps]				
good writing quality [cps]	1080	680	340	220
high writing quality [cps]	760	480	230	150
Step response time ⁽²⁾				
1 % of full scale [ms]	0.40	0.45	0.70	1.1
10% of full scale [ms]	1.1	3.0	1.9	2.5

(all angles are in optical degrees)

⁽¹⁾ with F-Theta objective, f = 160 mm ⁽²⁾ settling to 1/1000 of full scale

Precision & Stability (tuning dependent)

	intelliSCAN	intelliSCAN III	intelliSCAN _{de}	intelliSCAN _{se}
Repeatability (RMS) [μrad]	< 2	< 2	< 0.4	< 0.4
Positioning resolution [bit] ⁽³⁾	18	18	20	20
Nonlinearity	< 3.5 mrad/44°	< 0.9 mrad / 44°	< 0.5 mrad/44°	< 0.5 mrad/44°
Temperature drift				
Offset [μrad/K]		< 15 ⁽⁵⁾	< 15	< 15
Gain [ppm/K]		< 25 ⁽⁵⁾	< 8	< 8
Long-term drift				
8-h-drift (after 30 min warm-up) ⁽⁴⁾	< 0.6 mrad			
Offset [μrad]		< 100	< 20	< 20
Gain [ppm]		< 100	< 20	< 20
24-h-drift (after 3 h warm-up) ⁽⁴⁾				
Offset [μrad]		< 100	< 20	< 20
Gain [ppm]		< 100	< 25	< 25
Dither (position noise, RMS) [μrad]	< 5 ⁽⁶⁾	< 5 ⁽⁶⁾	< 1.6	< 2.0 ⁽⁷⁾

⁽³⁾ based on the full angle range (e.g. positioning resolution 2.8 μrad for angle range ±0,36 rad), resolutions better than 16 bit (11 μrad) only together with SL2-100 interface ⁽⁴⁾ at constant ambient temperature and load; achievable even under varying load when equipped with temperature-controlled water cooling ⁽⁵⁾ for intelliSCAN III 20 und 30: T-Offset < 20 μrad/K and T-Gain < 15 μrad/K ⁽⁶⁾ for micromachining tuning ⁽⁷⁾ intelliSCAN_{se} 14: 1.6

Common Specifications

Optical performance	
Typical scan angle [rad]	±0.35
Gain error [mrad]	< 5
Zero offset [mrad]	< 5
Power requirements	
intelliSCAN, intelliSCAN III	30 V DC, max. 3 A ⁽⁸⁾ or 48 V DC, max. 3 A ⁽⁸⁾
intelliSCAN _{de}	30 V DC, max. 6 A or 48 V DC, max. 6 A ⁽⁹⁾
intelliSCAN _{se}	30 V DC, max. 3 A
Interface	
	SL2-100, XY2-100 Enhanced
Operating temperature [°C]	
	25 ± 10

⁽⁸⁾ max. 6 A for intelliSCAN 20, 30, ⁽⁹⁾ max. 3 A for intelliSCAN_{de} 14;

SCANcalc App



Google Play App Store

06/2017 Information is subject to change without notice.
Product photos are non-binding and may show customized features.
Application picture: iStock.com/Viper161288;
Tuning pictures: Sharp-Edge: eos GmbH, Line-Scan: Trumpf GmbH + Co. KG